

△				
---	--	--	--	--

SPECIFICATION				
HOISTING LOAD		2 TON		
TESTING LOAD		2.5 TON		
LIFTING HEIGHT		Min. 3 M ~ Max 30 M		
HOISTING		SPEED	3.5 M/MIN	
		MOTOR	1.5 Kw x 4 P	
TRAVERSING		FAST	SPEED	19 M/MIN
			MOTOR	0.4 Kw x 4 P
		MIDDLE	SPEED	12 M/MIN
			MOTOR	0.27 Kw x 6 P
		SLOW	SPEED	9 M/MIN
			MOTOR	0.2 Kw x 8 P
POWER SUPPLY		3Φ-220,380,440,460,480V-60Hz		
CONTROLL VOLTAGE		1Φ -48,110V -60Hz		
OPERATING METHOD		PUSH BUTTON TYPE		
LOAD CHAIN SPEC.		Φ7.1 x 21P x 2 FALL		
WIDTH OF BEAM		100~125		
RADIUS OF BEAM		MIN. 1500 mm		
RATING		30 MIN.		
NET WEIGHT		APPROX Min.110KG~Max.160KC		

DIMENSIONS					
구분	양정(LIFT)				
	3M-11M	12M-16M	17M-20M	21M-30M	
기호					
C	615	800	960	1050	

MODEL : SMT-S2000

900	TROLLEY ASS'Y				1	
700	ELEC. ASS'Y				1	
600	HOIST MOTOR ASS'Y				1	
500	BUCKET ASS'Y				1	
400	BOTTOM HOOK ASS'Y				1	
200	GEAR BOX ASS'Y				1	
100	CENTER FRAME ASS'Y				1	
NO.	DESCRIPTION	MAT'L	SIZE	Q'TY	REMARK	
DRAWN	S.M.YOO	CHECKED	S.S.CH	SCALE	1/1	DWG. NO.
DESIGNED	S.S.CH	MM	INCH	DATE	2005.7.20	

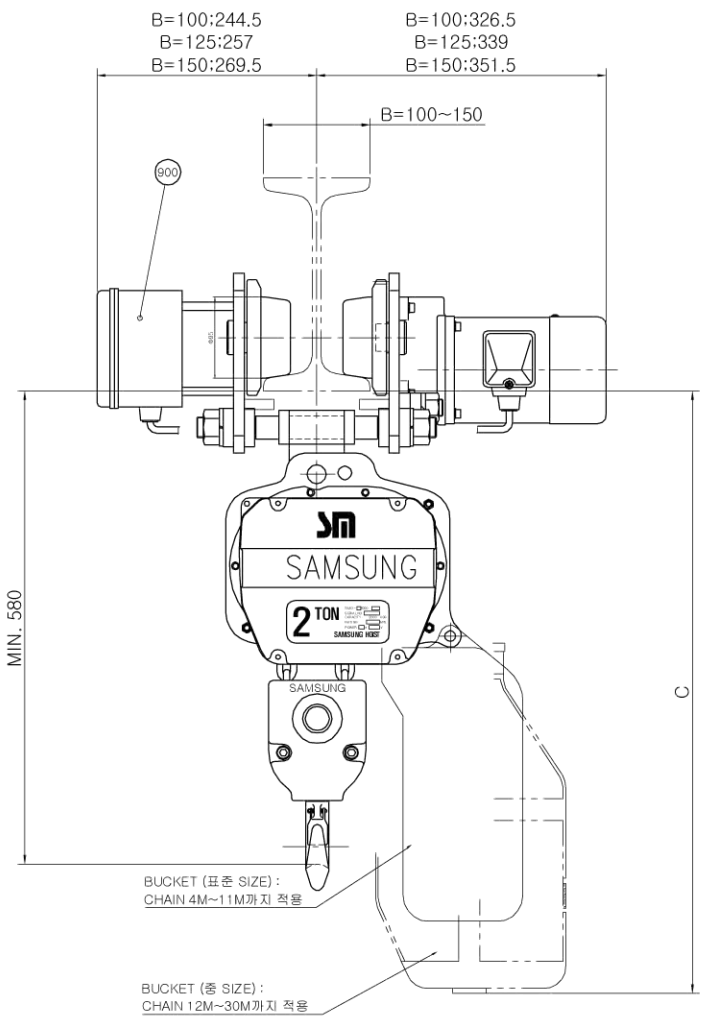
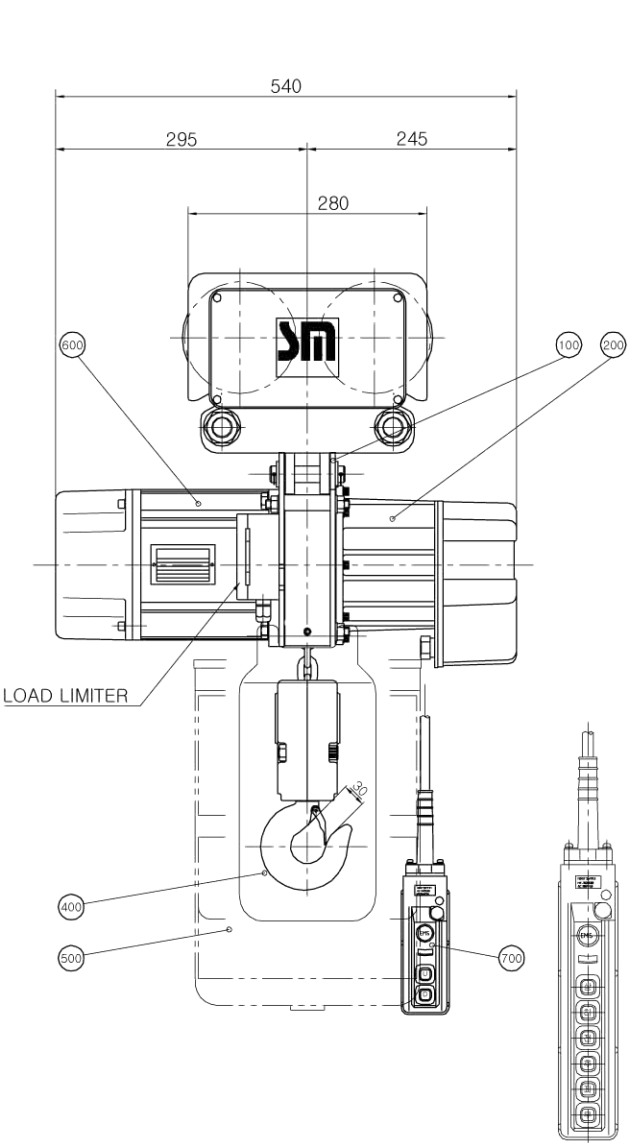

TITLE OF PROJECT 2 TON SUSPENSION SINGLE TYPE (LIFT : 3M~30M)
ELEC. CHAIN HOIST GENERAL ASSEMBLY