

△				
---	--	--	--	--

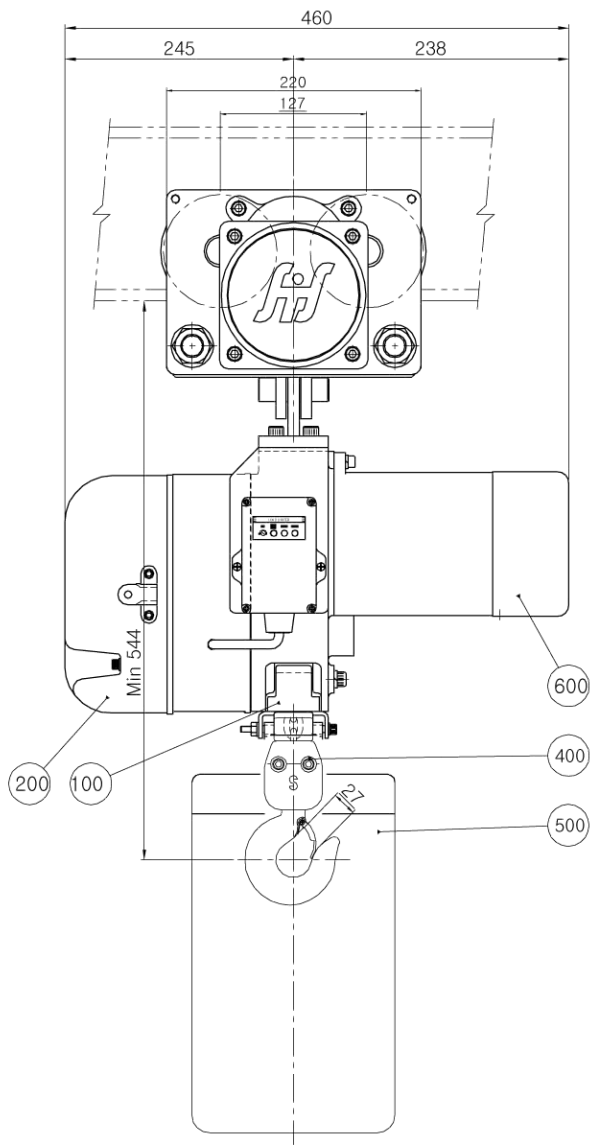

SPECIFICATION		
HOISTING LOAD	0.25 TON	
TESTING LOAD	0.313 TON	
LIFTING HEIGHT	Min. 3.5~20 M	
HOISTING	SPEED	8.4 M/MIN
	MOTOR	0.5 Kw x 4 POLE
TRAVERSING	SPEED	20 M/MIN
	MOTOR	0.2 Kw x 4 POLE
POWER SUPPLY	3Φ-220,380,440V-60Hz	
CONTROLL VOLTAGE	1Φ -110V -60Hz	
OPERATING METHOD	PUSH BUTTON TYPE	
LOAD CHAIN SPEC.	Φ5.0 x 15P x 1 FALLS	
RATING	30 MIN	
NET WEIGHT	Min. 53 KG	

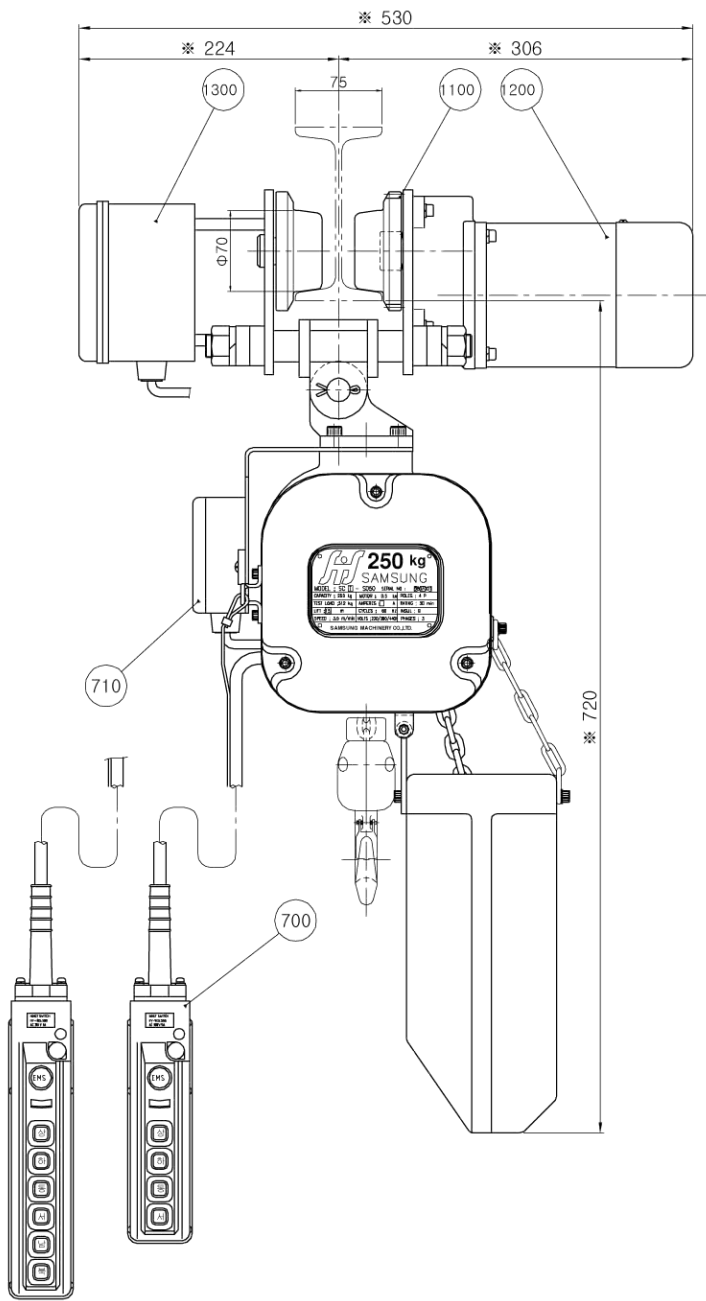

TITLE OF PROJECT 0.25TON MONO RAIL TYPE  
ELEC. CHAIN HOIST GENERAL ASSEMBLY

NO.	DESCRIPTION	MAT'L	SIZE	Q'TY	REMARK
DESIGNED	APPROVED	SCALE	DATE	DWG. NO.	
	권승현	1/1	2008.1.15		SCT-S250